

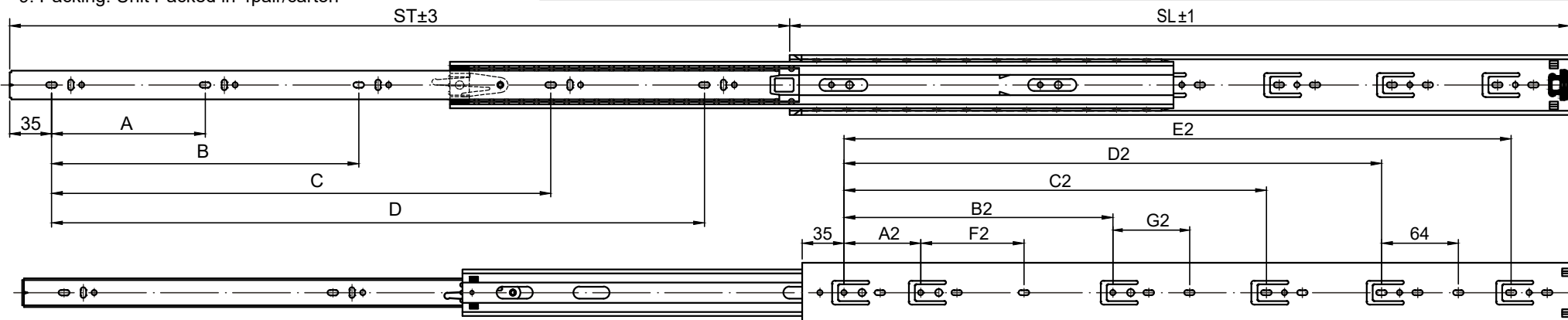

NOTES:

1. Length: 250mm to 1250mm(10" to 50")
2. Thickness: 1.5x1.5x1.8 mm
3. Travel: Full Extension
4. Max. Loading: 68kg(150lb)
5. Mount: Side Mount
6. Disconnect: Lever Disconnect
7. Finish: 316 Stainless Steel Original Color
8. Material: 316 Stainless Steel
9. Packing: Unit Packed in 4pair/carton

CODE	ST	SL	A	B	C	D	A2	B2	C2	D2	E2	F2	G2
RS50250	250	250	160	/	/	/	160	/	/	/	/	/	/
RS50300	300	300	96	192	/	/	64	224	/	/	/	96	/
RS50350	350	350	128	256	/	/	64	224	/	/	/	86	/
RS50400	400	400	128	320	/	/	64	224	288	/	/	86	/
RS50450	450	450	160	352	/	/	64	224	352	/	/	86	/
RS50500	500	500	192	416	/	/	64	224	352	416	/	96	64
RS50550	550	550	224	448	/	/	64	224	352	416	/	96	64
RS50600	600	600	224	512	/	/	64	224	352	480	/	/	/
RS50650	650	650	256	544	/	/	64	224	352	512	/	/	/
RS50700	700	700	288	608	/	/	64	224	352	480	608	/	/
RS50750	750	750	288	640	/	/	64	224	352	480	608	/	/
RS50800	800	800	256	512	704	/	64	224	352	480	672	/	/
RS50850	850	850	192	352	576	736	64	224	352	480	608	736	/
RS50900	900	900	192	384	608	800	64	224	352	512	672	800	/
RS50950	950	950	192	384	640	832	64	224	352	512	672	832	/
RS501000	1000	1000	192	416	672	896	64	224	384	544	736	896	/
RS501050	1050	1050	192	448	704	928	64	224	384	544	736	928	/
RS501100	1100	1100	192	448	736	992	64	224	384	576	800	992	/
RS501150	1150	1150	192	480	800	1024	64	224	416	608	832	1024	/
RS501200	1200	1200	224	512	832	1088	64	224	448	672	896	1088	/
RS501250	1250	1250	256	544	864	1120	64	224	448	672	896	1120	/



 中遠國際有限公司 TOOL & TECH INTERNATIONAL CO.,LTD.	Part Number: Series RS50	Drawn by:	Date:	Material:
	Description:	Checked by:	Projection Method:	Finish:

This drawing and any information or description material set out on it are the confidential and copyright property of TOOL & TECH INTERNATIONAL CO.,LTD.