

CODE	SL	ST	A	B	C	D	A2	B2	C2	P/C
RSF45300	300	248	64	-	200	-	96	-	-	15
RSF45350	350	315	96	-	250	-	72.5	55.5	-	15
RSF45400	400	380	128	-	300	243	128	55.5	-	15
RSF45450	450	446	160	125	350	-	128	96	-	15
RSF45500	500	496	192	128	400	310	128	96	64	15
RSF45550	550	546	192	192	450	334	128	96	96	15
RSF45600	600	600	224	192	500	358	128	96	128	15

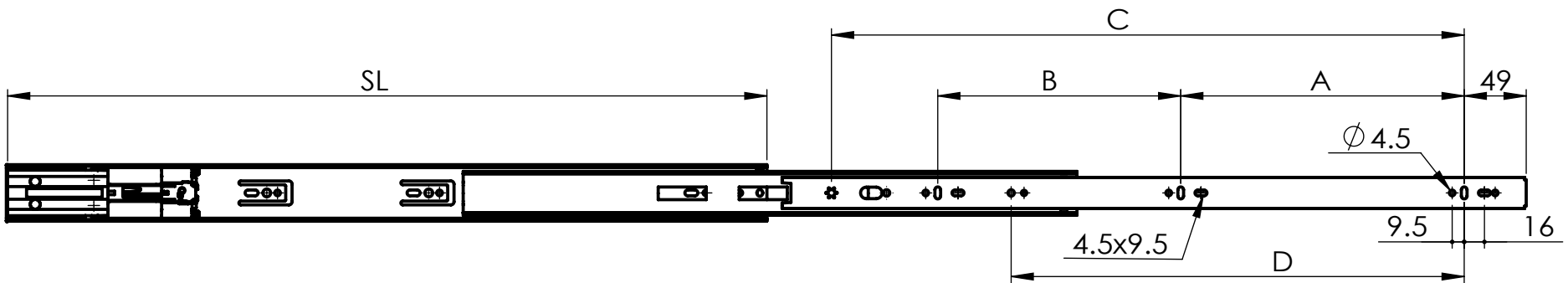
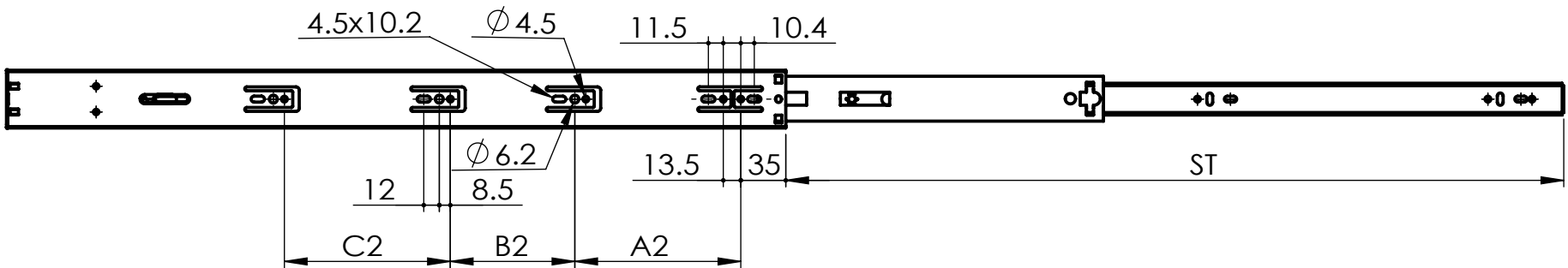
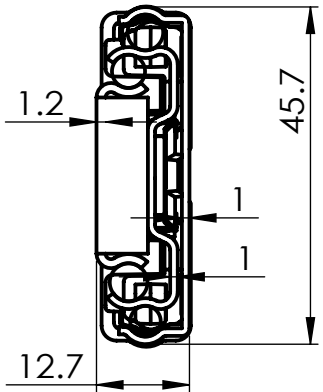

NOTES:

1. Length: 300mm to 600mm (12" to 24")
2. Travel: Full Extension
3. Max. Loading: 30kg (66lb)
4. Mount: Side Mount
5. Disconnect: Lever Disconnect
6. Finish: 304 Stainless Steel Original Color
7. Material: 304 Stainless Steel
8. Packing: Unit Packed in 15pair/carton

 中遠國際有限公司 TOOL & TECH INTERNATIONAL CO.,LTD.	Part Number:	Series RSF45	Drawn by:	Wen	Date:		Material:	
	Description:		Checked by:		Projection Method:		Finish:	

This drawing and any information or description material set out on it are the confidential and copyright property of TOOL & TECH INTERNATIONAL CO.,LTD.